

OWNERS MANUAL & INSTALLATION GUIDE

C2 COMBO with 50 mm ports

"COMBO" : THE BOSCH - EVERLAST COMMERCIAL GAS HOT WATER SUPPLY SYSTEM

Why !

- Reduced Energy Costs
- Reduced Capital Costs
- High System Reliability
- High Performance

Where !

- Motels / Hotels
- Laundrettes
- Sports Clubs
- Nursing / Aged Hon
and Large Resident

Hot Water Delivery

- Up to 4365 Litres in the
first hour (50 C temp rise)

ROBERT BOSCH (AUST) PTY. LTD

57 – 63 MC NAUGHTON ROAD CLAYTON VIC 3168

PH 03 9541 5555 FAX 03 9541 5595

www.bosch.com.au

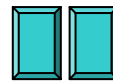

EVERLAST™ HYDRO SYSTEMS PTY. LTD

ABN 41 087 168 116

ACN 087 168 116

14 COMMERCIAL DRIVE DANDENONG VIC 3175

Ph 03 9768 2404

Fax 03 9768 2406

www.everlastwaterheaters.com

email: everlasthydro@everlastwaterheaters.com

Bosch - Everlast™COMBO Gas Hot Water System

Read this information in conjunction with **Bosch Continuous Flow Gas Heaters Installation & User Handbook**, and **pump manufacturers operating instructions handbook**.

The Bosch-Everlast™COMBO Commercial Gas Hot Water System is a combined Gas Continuous Flow water heating system and accumulator. The system has been manufactured to Australian Standards AG 102 and AS 1056.

The system incorporates a full copper heat exchanger for maximum life and a premium marine grade 316 stainless steel cylinder. The system is covered by a 10 year warranty in domestic installations, and 5 year warranty in commercial installations; as per the enclosed warranty conditions.

The combination of the high efficiency and powerful Bosch Continuous Flow hot water heaters with the durable, highly insulated Everlast C2 Accumulator, yields a high delivery, very long life hot water system.

The system can be sized to meet applications where far more expensive options would be the only other design alternatives.

Features of your Bosch - Everlast™ COMBO Water Heating System

- This system provides both flow and temperature buffering from a 250 or 315 litre Accumulator so that high peak hot water draw-offs and high average peak flows do not result in flow or temperature fluctuations. (Actual capacities of Accumulators exceed the rated sizes by about 20 litres).
- Systems with an Accumulator deliver stability under peak demand extremes without the need to over design a non accumulator system.
- Multiple Bosch Continuous Flow units may be manifolded to the Everlast Accumulator with No need for Staging of the Cold Water Supply Inflow, as the Total flow of the manifolded units has to be circulated through the Accumulator to ensure best buffering and recovery performance.

- The Accumulator design has exceptional thermal insulation to meet Australian Standard AS 1056, and the gas units have no heat loss when burners are off. As a result, this system is highly efficient with almost no "standing or waste" heat losses and of course absolute minimum heat wastage in storage to meet peak use.

- Modular design. The Everlast C2 Accumulator, the Bosch Continuous Flow units and the Circulating Pump such as Davey SB30-25 & Grundfos 32-80B; are ALL separate components and are independently serviced for replacement or repair. No unitary system high replacement costs.

- 50 mm primary flow fittings oriented for commercial manifolding with a minimum of coupling tees or size change socket fittings.

- Technical Support. Available from Everlast, to assist you in design, component selection and specification. Bosch Continuous Flow manufacturers technical service will provide system information on units, performance and flueing options for internal units and hot water accessories.

The Bosch-Everlast™COMBO Water Heating System uses Bosch Continuous Flow water heaters typically from 132 – 200 MJ/hour. Multiple Bosch units can be manifolded together with one Everlast C2 Accumulator. When a Single Bosch unit is required an Accumulator is available with integrated mounting points and with the addition of the Pipe cover, a space saving, secure and aesthetic package is presented. As a design example :

A COMPLEX OF TWENTY-FIVE 3 BEDROOM APARTMENTS INCLUDING ENSUITES IS FULLY SERVICED BY THREE 200 MJ/HR MODEL 25 E HEATERS & TWO 315 L C2 ACCUMULATORS.

" COMBO " Water Heating System

There are three main water "circuits" in the Bosch-Everlast COMBO Water Heating System :

a) The "Mains Pressure" Circuit - causes water to flow from the 'mains supply' to the Accumulator cylinder and from the Accumulator cylinder to the system outlets. Diagram 1 shows the "Mains Pressure" circuit.

The "Primary Circulation" Circuit - causes water to flow through the gas heating process. The Primary Circulation Pump sources its water from the Accumulator cylinder or the mains supply or both.

(This will depend on the flow rate through the mains pressure circuit). Because heated water is always discharged to the Accumulator the delivered temperature is very stable. Diagram 2 shows the Mains Pressure + Primary circuits.

b) The "Secondary Circulation" Circuit (this is only required where there is a need for secondary pipework reticulation i.e. hot water flow is maintained in a loop through all outlets). In these installations the secondary return is connected to the hot water primary flow pipe to ensure the hot water that is circulating does not short circuit the mix into heated water. Diagram 3 shows the Mains Pressure + Primary + Secondary circuits.

Notes for the following Water flow circuit diagrams :

Applications

In applications where hot water supply is direct and non-recirculated, such as some motels, laundrettes, hospitals and sports club showers; the mains pressure and primary circuits provide a simple system capable of very high delivery and heat transfer.

In applications where hot water is to be circulated past the outlets, such as some motels, apartments and very large homes; the secondary circulating pump and circuit provides immediate hot water delivery at each outlet with this minor addition to the system. Usually made in-situ, this circuit is additional to the Integrated Package and is not provided in the Bosch-Everlast Integrated Package.

Tempering or Thermostatic mixing valves

In accordance with Australian Standard AS 3500.4, it is recommended that where required a temperature control device or mixing valve be fitted between the water heater and bathrooms and ensuite to reduce the risk of scalding. This is achieved by controlling water temperature to below 50 degrees C. The locations as shown on the Water flow circuit diagrams are where required at point of use in the mains pressure circuit.

To ensure there is no conflict with thermostat set temperature of the COMBO system, they are not associated with the primary or secondary circulation circuits.

Expansion Relief Valve.

A 750 – 850 kPa expansion relief valve is recommended in the Primary Circulation Circuit which is transferring heated water into the Accumulator. The valve allows for expansion of water in the primary piping loop during the heating cycle. Discharge may occur during heating and is normal.

Pressure and temperature relief valve (PTR)

A Pressure Relief Valve is located on the Hot Water Outlet connection of each Bosch Heater Unit in accordance with AG 102, to prevent pressure damage to the heat exchanger.

The COMBO Accumulator cylinder features dual 20 mm PTR ports. Two 850 kPa PTR valves are provided to meet requirements in accordance with AG 102 Sec 2.7.10. State Regulations may require the installation of two PTR valves and/or PTR valves in the piping manifold configuration. If only one PTR valve is required, the second provides safe redundancy or a blanking plug may be substituted. The PTR valve pressure setting should always be 850 kPa.

Pressure limiting valve

A 500 - 600 kPa Pressure Limiting valve must be fitted, to ensure correct function of the system in conjunction with the PTR valve / Expansion Relief valve.

As shown in the Water Flow Circuit Diagrams, isolating valves for ease of service, line strainers and non return valves are recommended as good installation practice and to ensure protection of pumps from contamination or damage in the event of water system pick up of contaminants.

Installation must comply with Australian Standard AS 3500.4 - National Plumbing Code, and any local authority regulations.

Tempering or Thermostatic Mixing valves as required for Safety Temperatures in areas used primarily for the purposes of personal hygiene as defined in AS3500 or by Industry or local regulations

All hot & cold water supply pipework shown in this diagram to be sized and installed in accordance with AS3500 and local and industry regulations to ensure adequate flow to the buildings outlets.

Pressure & Temperature Relief Valve or Valves in accordance with AG102 & as required by State Regulations. Two 20 mm PTR Ports provided

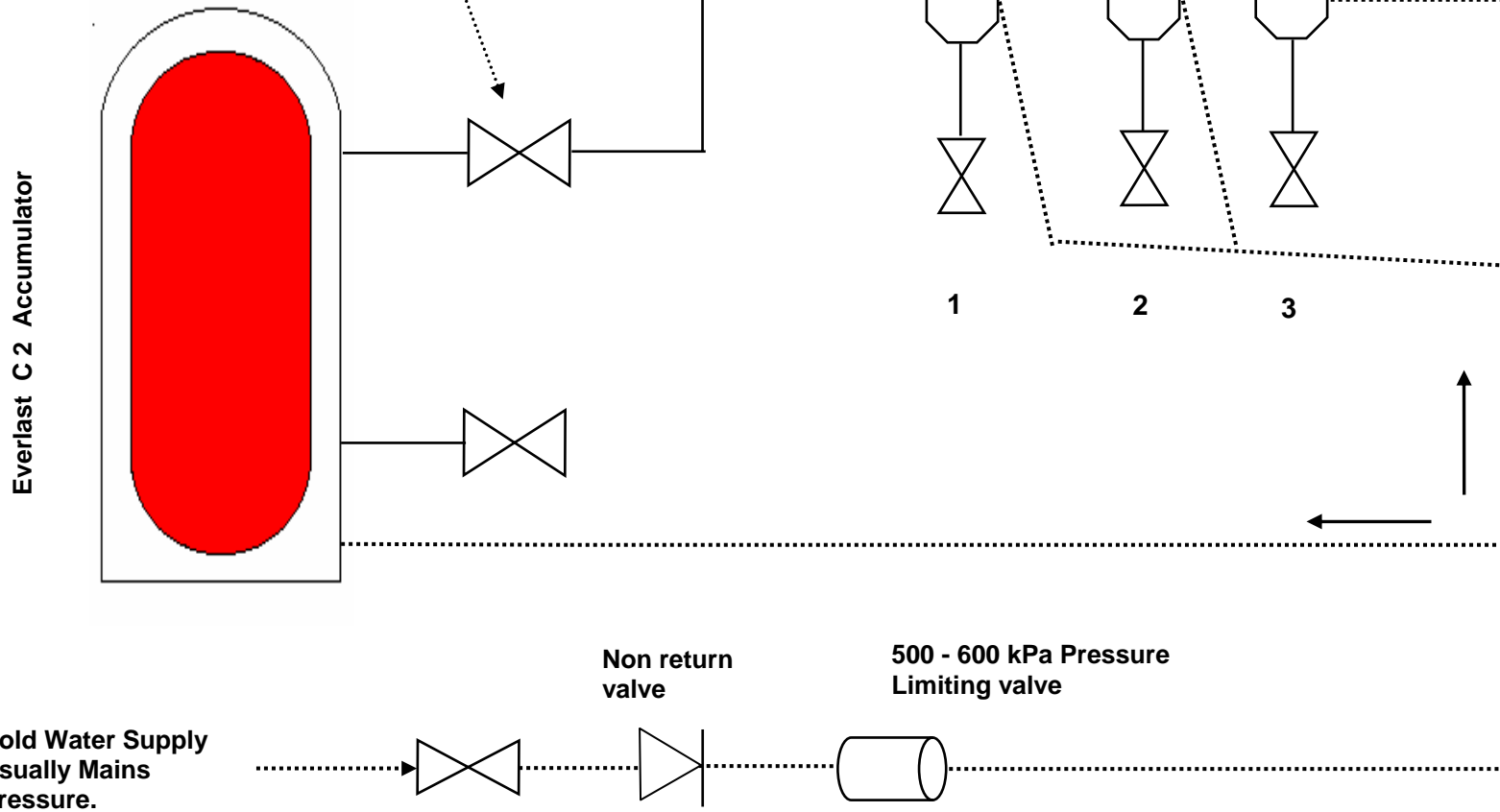

This design shows 3 building outlets numbered 1, 2 & 3 for illustrative purposes only

LEGEND :
 Cold Water Supply

 Hot Water Supply :

DIAGRAM 1. WATER MAINS PRESSURE CIRCUIT

External or Internal Bosch Continuous Flow Water Heater(s). Manifolder if required in accordance with manufacturers recommendations. PTR valves in accordance with AG102 & as required by State Regulations.

Tempering or Thermostatic Mixing valves as required for Safety Temperatures in areas used primarily for the purposes of personal hygiene as defined in AS3500 or by Industry or local regulations

All hot & cold water supply pipework shown in this diagram to be sized and installed in accordance with AS3500 and local and industry regulations to ensure adequate flow to the buildings outlets.

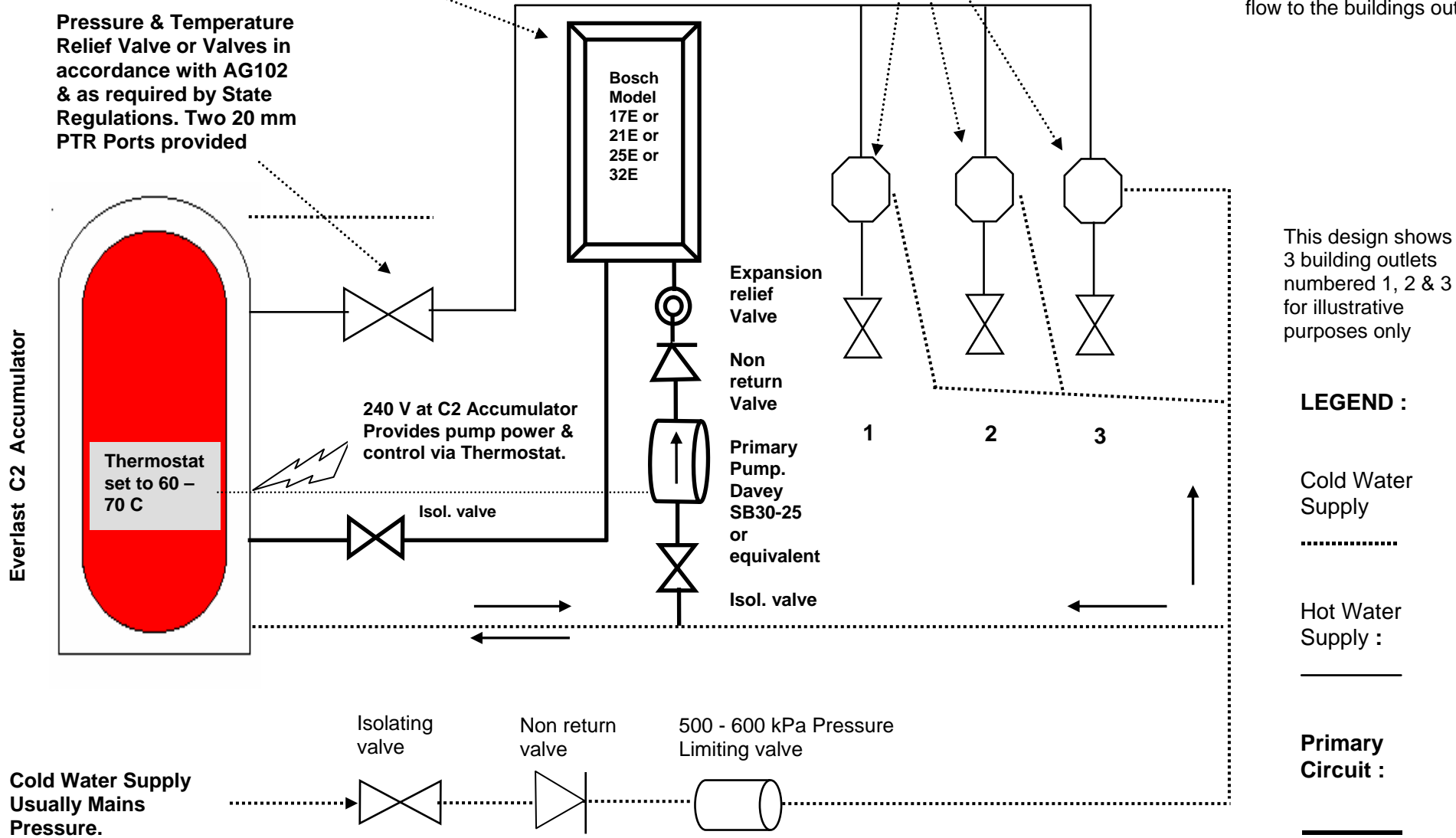

DIAGRAM 2. WATER MAINS PRESSURE plus PRIMARY CIRCUIT

External or Internal Bosch Continuous Flow Water Heater(s). Manifolled if required in accordance with manufacturers recommendations. PTR valves in accordance with AG102 & as required by State Regulations.

Tempering or Thermostatic Mixing valves as required for Safety Temperatures in areas used primarily for the purposes of personal hygiene as defined in AS3500 or by Industry or local regulations

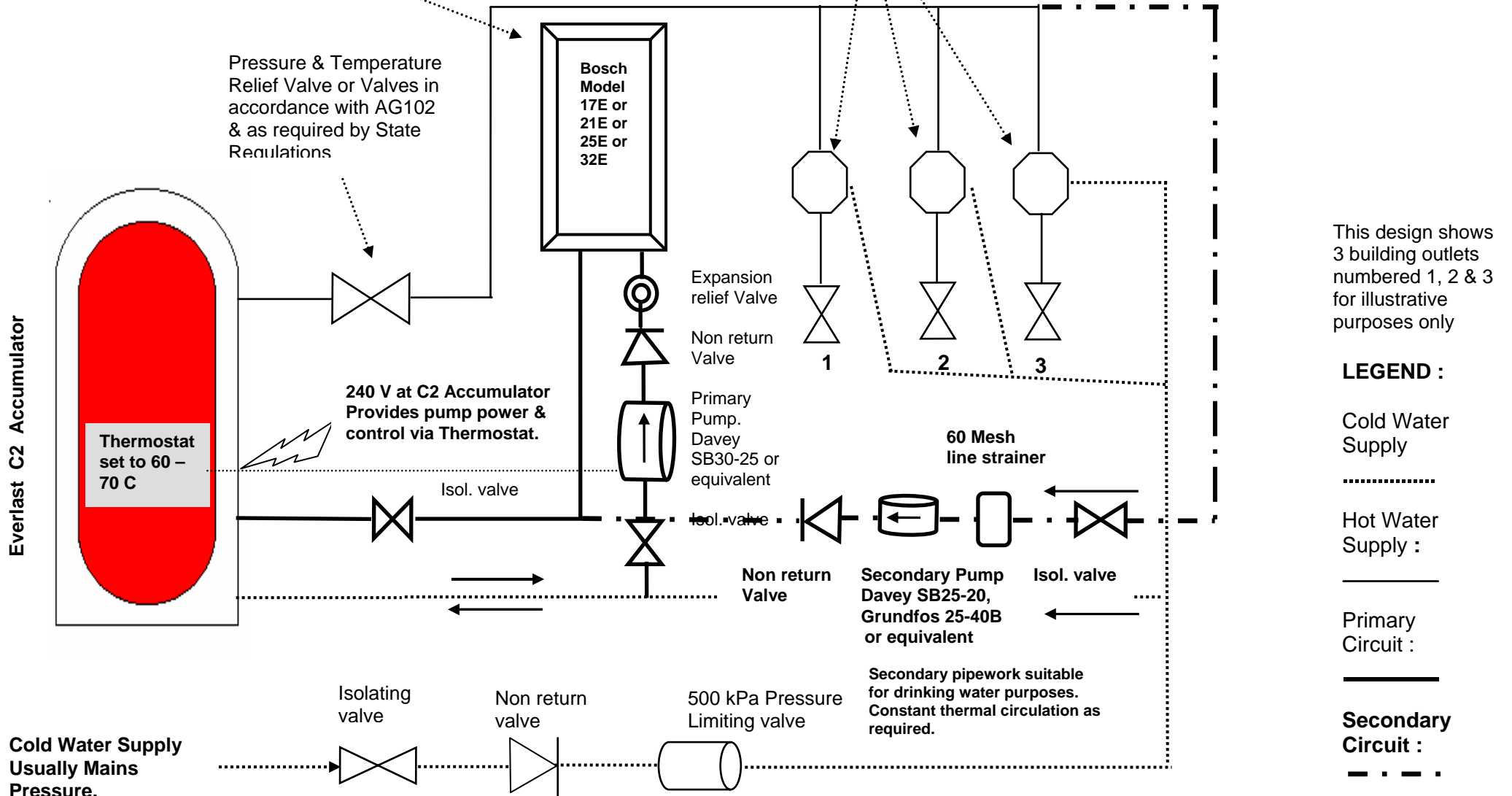

DIAGRAM 3. WATER MAINS PRESSURE plus PRIMARY CIRCUIT plus SECONDARY CIRCUITS

COMBO System Capability

The following chart will assist in the selection of the COMBO System that meets with your specific requirements.

Even if you have specified a basic COMBO System with a single Bosch Continuous Flow Water Heater and the Everlast Accumulator and then your hot water delivery requirements increase; or if the hot water demand is not immediately known; this is a System where, if required, a further Bosch Continuous Flow Water Heater may be added.

HOT WATER DELIVERY CHART

COMBO with Bosch 17E, 21E or 25E Gas Heater Units & one Everlast 250 Litre C2

Figures based on heating from 15 °C up to 65 °C (fairly typical)

COMBO Unit Model	Heat up Time (mins)	Burner Size (MJ / hour)	Tank Capacity (Litres)	First hour delivery (Litres)	Further hourly delivery (Litres/hr)
250117E	36	132	250	784	534
250121E	29	160	250	898	648
250125E	24	200	250	1060	810

**** Notes for tables:** Motel rooms will be a mixture of 1 bedrooms with 1 or 2 people showering (business accom. is typically 1 person); and 2 bedrooms with 2 or 3 persons showering. Therefore to average at 2 persons per room is conservative, safe design.

These are scenarios ranging from small motel/hotel/unit developments up to significant multi room accommodation; serviced with very efficient hot water plant .

3 Star Accommodation equals 30 Litres per person per Peak Hour

5 Star Accommodation equals 45 Litres per person per Peak Hour

COMBO with Bosch 17E, 21E or 25E Gas Heater Units & one Everlast 315 Litre C2 Figures based on heating from 15 °C up to 65 °C (fairly typical)

COMBO Unit Model	Heat up Time (mins)	First hour delivery (Litres)	Further hourly delivery (Litres/hr)	Typical Number of motel/hotel rooms assuming 2 persons per room showering. **	
				3 STAR ACCOM.	5 STAR ACCOM.
315117E	36	849	534	14	9
315121E	29	963	648	16	11
315125E	24	1125	810	19	13

[Reference: Robert Bosch (Australia) Pty Ltd]

COMBO Pipe and Fittings Sizing Guidelines

The Bosch-Everlast™ COMBO Gas Hot Water System relies on the Everlast Accumulator which will accommodate from one to 5 Bosch Continuous Flow Water Heaters.

Specified in conjunction with the Grundfos UPS 32-80 B pump, a system may be assembled with consistent pipe and fittings sizing.

The 50 mm sizing of Primary Circulation piping in the COMBO design, ensures that the system will meet the range of major commercial applications of single or multiple Gas units; manifolded to the COMBO. Connection may be made using 50 mm direct coupling as required. The factors to be considered by the Installer are the mains supply piping/flow rates, and Secondary Circuit piping, if required.

The following design principles should be considered in the determination of the mains and secondary piping sizes :

If pipework is undersized for the required flow (litres/sec) or (litres/min), then the velocity will increase (metres/sec) resulting in an increased pressure loss. If pipework is oversized for the required flow, then the heat loss will be increased.

The Bosch Continuous Flow Water Heater Manuals available from Robert Bosch Australia; and the publication "Selection and Sizing of Copper tubes for water piping Systems" by B. Smith, available from Copper & Brass Information Centre, or Institute of Plumbing Australia; are helpful publications.

Whilst major systems do require the input of competent hot water system designers, the application of the Guidelines in the above publications and particularly the Guidelines for Installation in the Bosch Continuous Flow Water Heater Manuals will facilitate good design in respect to Pipework.

COMBO System Pump, Flow & Pressure characteristics.

Primary Circulation Circuit. Typical for the 160MJ units.

No of 160 MJ units	Assumed Flow Rate Litres per min	Pressure Loss kPa	Typical Pump Model & Speed Setting	Basis of the Pressure & Flows in Primary Pipe Sizing and approximate lengths.
1	10-20	30-40	DaveySB30-25 Speeds 1 & 2	25 mm pre-fitted Integrated Package.
2	20	34	Gfs UPS32-80B Speed 2	32 mm tube up to a length of 20 metres & 20 mm tube at Gas Units up to 3 metres, yields very small pressure drops. Greater lengths may be calculated.
3	30	38	Gfs UPS32-80B Speed 2	
4	40	42	Gfs UPS32-80B Speed 2	
5	50	46	Gfs UPS32-80B Speed 2	

These Davey & Grundfos pumps are multi speed pumps where pump speed may be matched to system design (see above). They have a bronze body and brass connections. Refer to the Davey & Grundfos Pump Manuals for single speed and Secondary Piping Circulator pump alternatives.

Internal Installation Water Safety

For internal (indoor) installations of Accumulator, a safe tray is recommended in accordance with Australian Standard AS 3500.4 This is necessary to prevent damage associated with a leaking pump or fittings, or when flushing the Accumulator.

Secondary Circulating Pump and Pipework

The secondary circulating pump and pipework (where required) will always be sized to produce the flow rate that has been determined from system heat losses and draw off's that provides acceptable temperature drop before return.

The Davey SB30-25 multi speed pump may be utilised for secondary circulation, or when secondary pipework is 25 mm or 18 mm, the SB25-20 or Grundfos equivalent may be preferable such as the UPS 25-40B, UPS 25-60B & UP 25-80B. Flow characteristics to suit the system may be selected from the manufacturers Circulator Pumps Handbooks. These handbooks incorporate flow curves for each pump which may be relied upon to suit the hot water circulation requirements of the system.

Electrical Connection & Wiring

The Bosch-Everlast™ COMBO Commercial Gas Hot Water System is designed for single phase 240 V. A.C. supply only. Australian Standard AS 3000 – (Wiring Code), and local supply authority regulations apply.

Notes for the following Schematic Wiring Plans :

240 V AC Supply is required at the point of connection of the Accumulator Thermostat for the operation of the Primary Circulating Pump. Where a Secondary Circulating Pump is required, the AC supply to this pump must be located in close proximity to the pump.

Connection is made at the terminal location points under the IP rated weatherproof thermostat cover. Wiring entry to the connection point is made through the blanked-off standard conduit port adjacent to the thermostat cover, by removal of the blanking plug. Always install a standard 20 mm conduit elbow to the port to ensure conduit support.

240 V AC Supply may be required at the point of connection of the Gas Continuous Flow Water Heater(s) to energise the electronic burner ignition system.

High Temperature Hot Water Applications are referred to the further schematic for the high temperature thermostat, and the notes therein.

BOSCH - EVERLAST

COMBO MODEL

SCHEMATIC WIRING PLAN

TESTING : The pump will operate until the thermostat set temperature of the Everlast Storage Accumulator is reached. When testing the thermostat there will be a CLOSED CIRCUIT between L4 and T2 until the thermostat set temperature is reached. There should be 240 V AC between L1 and L3 when the system is energised.

Refer to Gas Unit manufacturers recommendations for multiple heater units and when secondary return pumping is required.

Information on troubleshooting is found in the Pump and Gas Heater User Handbooks (provided with this Guide).

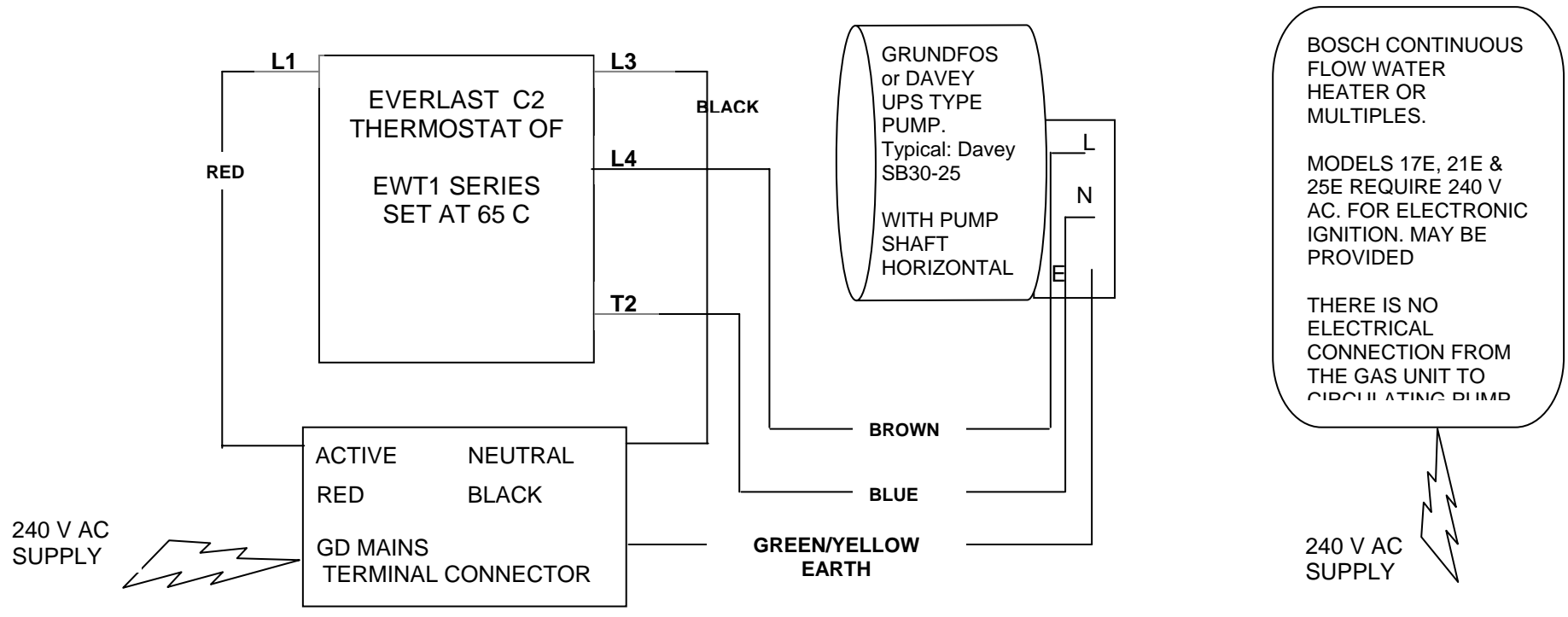

PAGE REV : 2

BOSCH – EVERLAST

COMBO HIGH TEMP MODEL

SCHEMATIC WIRING PLAN

APPLICATIONS : Commercial Process, Industrial or Dairy Industry etc. water heating to supply at 90 °C.

TESTING : The pump will operate until the thermostat set temperature of the Everlast Storage Accumulator is reached. When testing the thermostat there will be a CLOSED CIRCUIT between 1 and 2 until the thermostat set temperature is reached. This is a 240 V AC series application without over temperature thermal cut out. This is intended for high water temperature delivery systems. Safety Pressure and Temperature Relief Valves as specified in AG 102, must be installed into pipework.

Information on troubleshooting is found in the Pump and Gas Heater User Handbooks (provided with this Guide).

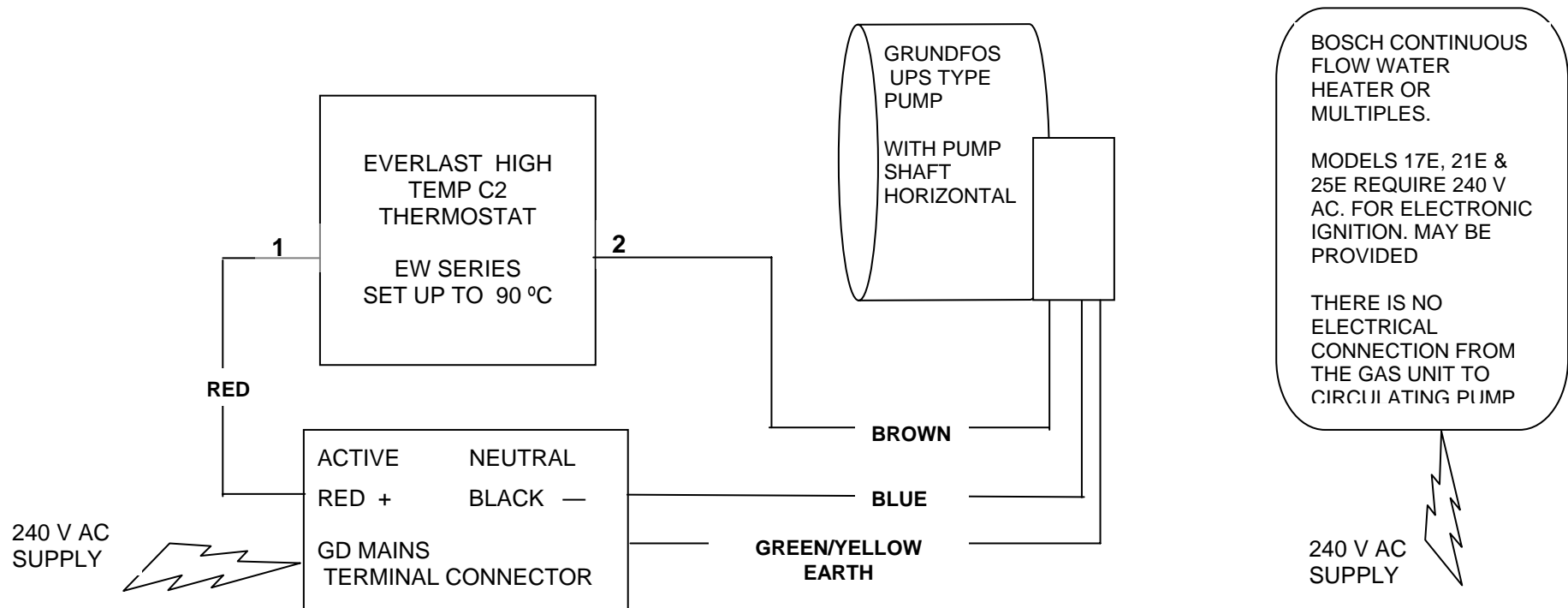

PAGE REV : 1

Gas Connections & Gas Piping

The Bosch-Everlast™COMBO Commercial Gas Hot Water System incorporates Bosch Continuous Flow Water Heaters which are Type A Appliances in accordance with AG 102. The Bosch Continuous Flow Water Heaters are produced for connection to Natural Gas and for connection to Liquefied Petroleum Gas (LPG).

The Installation requirements of AG 601 - The Gas Installation Code, apply to all general work & safety requirements, materials & gas piping, installation of gas piping, appliance installation and commissioning.

The Technical Services Division of Robert Bosch Australia provides a service for Information Support in regard to Gas connection and piping requirements to the Gas units.

INTEGRATED HEATER MOUNTING (C2 – 32 mm units only) This feature is not available on 50 mm outlet units

A feature of the Bosch-Everlast™COMBO Commercial Gas Hot Water System is Integrated Heater Mounting located on the side of the casing. These are secure, load bearing positions for the Continuous Flow Water Heater. The Integrated Heater Mounting locates the (optionally supplied) Heater Support Bracket, and is designed to ensure stable support of the Heater and pipe mounted primary pump for freestanding design where Systems are externally located. The attachment points of the Integrated Heater Mounting are stud-fitted and the Heater Support Bracket is predrilled for correct alignment using the supplied dome headed nuts. A schematic is shown below.

Simply determine the position of the Bosch Continuous Flow Water Heater and mount your Heater on the Support Bracket.

Maintenance

Maintenance of the system is limited to the periodic recommended draining and flushing of the Accumulator in areas of poor water quality and sediment in water supply. Bosch Continuous Flow Water Heater maintenance requirements as outlined by the manufacturer of the Gas unit(s) adopted, should also be complied.

HEATER SUPPORT BRACKET MOUNTING DETAIL :

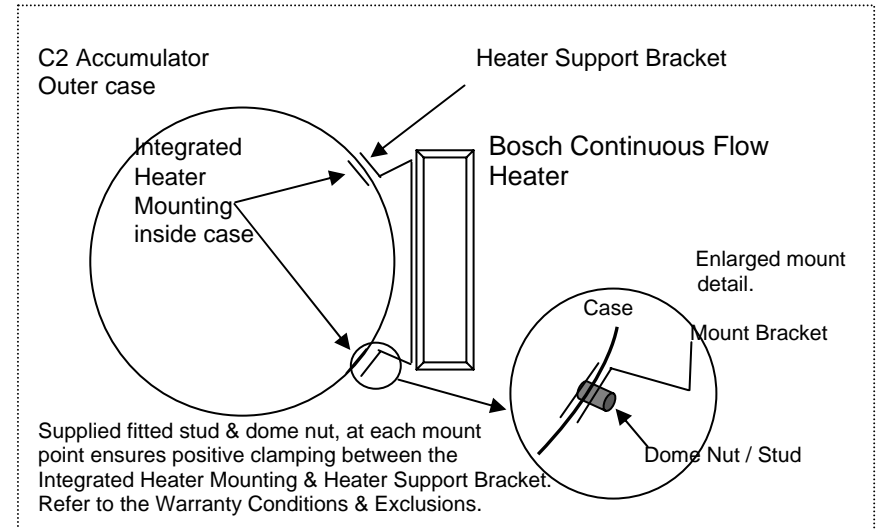

Warranty Conditions

1. The system must be installed by a licensed plumber and/or electrician in accordance with Bosch Continuous Flow Water Heater manufacturers & Everlast™ installation instructions; and all relevant statutory and local requirements of the State in which the system is installed.
2. The Bosch-Everlast™COMBO Commercial Gas Hot Water System must be operated and maintained in accordance with instructions supplied by Robert Bosch (Australia) Pty Ltd & Everlast™ Hydro Systems Pty Ltd
3. The Accumulator is warranted to be defect free for a period of 10 years in domestic installations, and 5 years in commercial installations. This warranty only applies to the Accumulator product and does not apply to any additional electrical, gas and/or plumbing parts supplied by the installer. The Bosch Continuous Flow Water Heaters are warranted as detailed in the manufacturers handbook.
4. The system is covered for the indicated period from the date of the original purchase.
5. Should this system be installed in a regional location where regular flushing is required due to sediment build-up, then a drain cock or tee for flushing must be fitted at the time of installation. If in doubt consult your Installation Contractor.

6. Where the heater is installed outside the boundaries of a Capital Cities Metropolitan area i.e. those areas on STD, the cost of transport, insurance and travelling between the nearest Everlast™ accredited Service Agent's premises will be charged to the owner.

Warranty Exclusions

The following warranty exclusions may cause the system warranty to become void. This may incur a service charge and cost for parts should they be necessary.

1. Where service is required to reconnect the water heater operation due to problems related with abnormal water supply (i.e. high water pressure), faulty plumbing, gas connection and/or electrical wiring, or major variations in electrical energy supply.
2. Where a pressure limiting valve as shown in the water circuit diagrams, has not been fitted during installation.
3. Where the system fails due to misuse, accidental damage, acts of God, incorrect installation or unlicensed service repair work attempts.
4. Where system service is required due to the non-conformance with this warranty's recommended maintenance in certain water quality conditions (refer warranty condition 5).
5. Claims for damage to walls, foundations (outside), furnishings (inside), roofs or other losses, directly or indirectly due to leakage from the COMBO Gas water heater/accumulator system.
6. Damage or breakage is not covered by this warranty, and should be added separately to your general household insurance policy.
7. This warranty does not cover the effects of sludge/sediment, or mineral salts as a result of connection to a water supply from unfiltered sources i.e. spring, dam, bore, river or other unreticulated supply.
8. Where water stored in the cylinder exceeds the following levels : -

Total dissolved solids	600 mg/litre or p.p.m.
Electrical Conductivity	850 uS/cm.
Total hardness	200 mg/litre or p.p.m.
Chloride	250 mg/litre or p.p.m.
Magnesium	10 mg/litre or p.p.m.
Sodium	150 mg/litre or p.p.m.
pH	Min 6.5 and Max 8.5

9. The benefits conferred by this warranty are in addition to all other rights and remedies in respect of the product, which the purchaser has under the Trade Practices Act (Commonwealth) 1975, and similar State or Territory Laws.
10. Where the Support Bracket connection to the Integrated Mounting Points is incorrectly installed or the Heater and/or bracket is mounted directly onto the outer casing and not at the Integrated Mounting Points.
11. Where PTR valves are not installed in the hot water outlets(s) from the heater(s) in accordance with AG 102.

Component Warranty Cover*	Single Domestic Application	Single/Multi Commercial Application
Free replacement of faulty Components or, where applicable, Free replacement of water heater Including labour	One year	One year
Accumulator Warranty Cover*	Single Domestic Application	Single/Multi Commercial Application
Should the COMBO stainless steel Accumulator rupture, a new unit will be supplied free Of charge. Total installation costs will be a cost to the owner.	Year One to year Ten Inclusive	Year One to year Five Inclusive

* Where the heater is installed outside the boundaries of a Capital Cities Metropolitan area i.e. those areas on STD, the cost of transport, insurance and travelling between the nearest Everlast™ accredited Service Agent's premises will be charged to the owner.

Further Information :

EVERLAST™ HYDRO SYSTEMS PTY. LTD.
 14 COMMERCIAL DRIVE DANDENONG VIC 3175
 Ph: (03) 9768 2404 Fax: (03) 9768 2406
www.everlastwaterheaters.com

ROBERT BOSCH (AUST) PTY. LTD
 57 – 63 MC NAUGHTON ROAD CLAYTON VIC 3168
 Ph: (03) 9541 5555 Fax: 03 9541 5595

www.bosch.com.au

Good . Better . Bosch

